

# THE SPAAR COUNTDOWN JAN '89

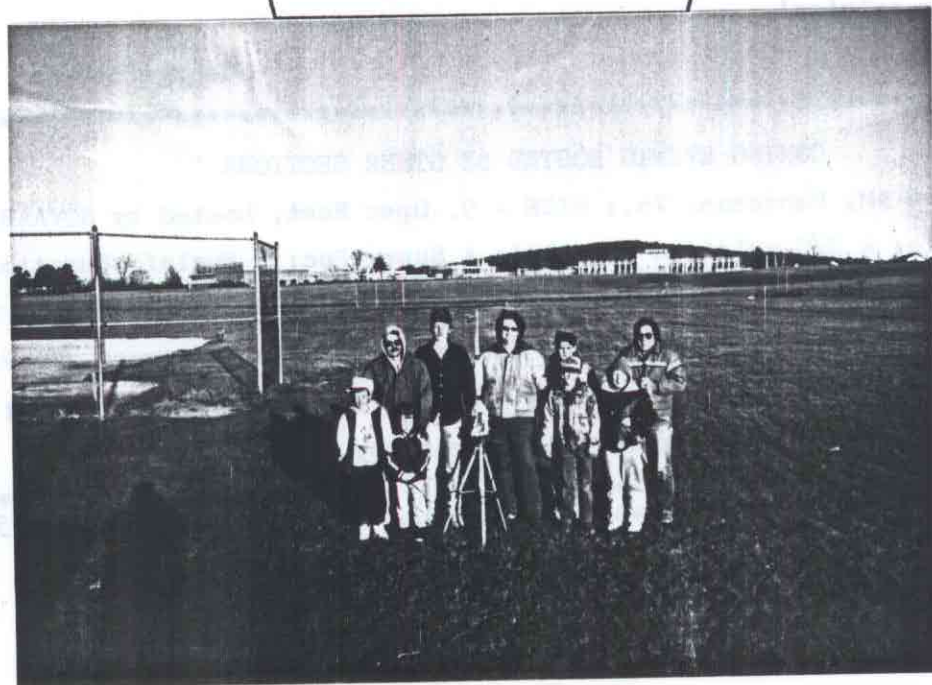
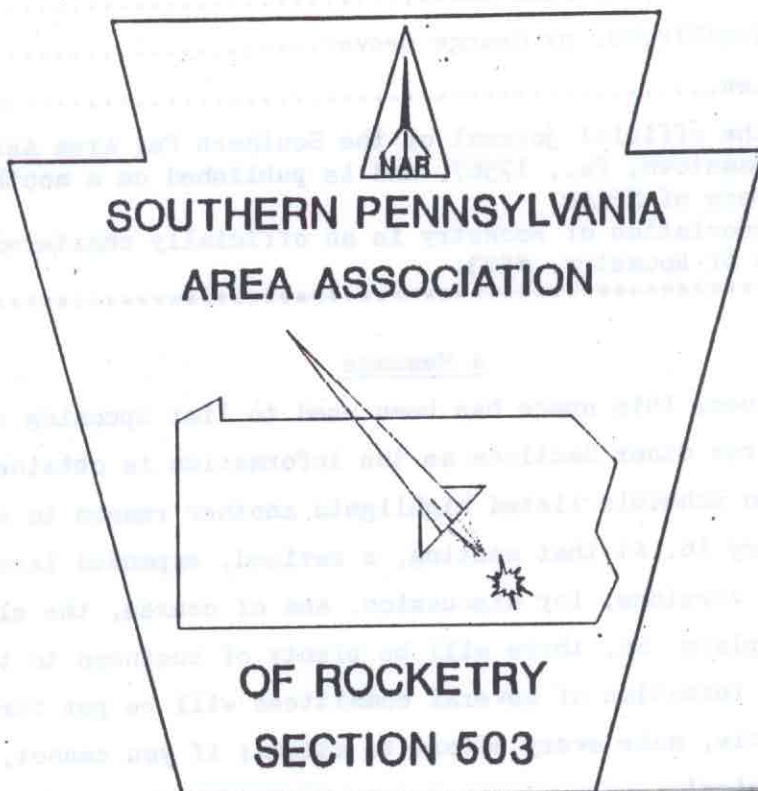

Vol. 1, No. 8

THE SPAAR COUNTDOWN

Volume 1, Issue 8

January, 1989

CONTENTS:

Section Meeting Minutes, 19 December, 1988..... Page 1  
Section Launch Activities & Flight Log, 18 December, 1988..... Page 1,2  
Election of Officers & Election Ballot..... Page 2  
Section News Notes..... Page 3  
Sport Plan - The DELTA STAR<sup>III</sup>, by John Yost..... Page 4  
Competition Plan - The TURKEYBIRD, by George Beever..... Page 5  
Statistics: 1988 in Review..... Page 6

The SPAAR Countdown is the official journal of the Southern Pa. Area Association of Rocketry, PO Box 127, Reamstown, Pa., 17567, and is published on a monthly basis as a service to the members of SPAAR.

The Southern Pa. Area Association of Rocketry is an officially chartered Section of the National Association of Rocketry, #503.

\*\*\*\*\*

A Message

In the last few issues, this space has been used to list upcoming events, from this Section, and from other Sections as the information is obtained by use. The fact that there is no schedule listed highlights another reason to attend the Section Meeting on January 16. At that meeting, a revised, expanded launch schedule will be proposed, in two versions, for discussion. And of course, the election of officers for 1989 will also take place. So, there will be plenty of business to take care of. Also, a proposal for the formation of several committees will be put forward.

So, if at all possible, make every effort to attend; if you cannot, call a fellow member to voice your opinion!

- George Beever

\*\*\*\*\*

COMING EVENTS HOSTED BY OTHER SECTIONS

Saturday, April 22, 9 AM, Manassas, Va.; NICE - 9, Open Meet, hosted by NOVAAR;  
Events: 1/2A RG; B Helo; A B/G multi; A SD multi; A Super Roc; B Eggloft Duration.  
Sat./Sun., May 20-21, Manassa, Va.; ECRM-16, hosted by NOVAAR; dress rehearsal for  
NARAM-31, which is to be hosted by NOVAAR at the same location in August, 1989.  
Events: B Alt; D Eggloft Altitude; C Payload; A R/G; C SD; Sport Scale; 1/2A PD;  
A Flexwing B/G. CD is Trip Barber, sport fliers welcome.

\*\*\*\*\*  
Just a reminder that dues are as follows: 14 years old & under: \$5 per year; 15,16 & 17 years old: \$7 per year; 18 years and older, \$10 per year.

On the cover: SPAAR's official logo, as of 12/18/88

### Section Meeting Minutes

The Southern Pa. Area Assoc. of Rocketry held it's monthly meeting on Monday, December 19, 1988, at the Lancaster County Library. Members present: John Yost, Daniel Yost, Ed Miller, Dale Greene, Dick Rhoat, Rick Hackman, Bryon Beiler, Dave Wenrich, Jess Wenrich, Glenn Feveryear, George Beaver. (11). The meeting began at 7 PM.

The members' suggestions for a color scheme for the Section logo were discussed. A basic blue and gold combination was agreed upon.

John Yost was thanked for donating the two cartoons that appeared in the December issue of the Countdown. Thanks also went out to Bill Rhoat for his contribution of the plan for his "Jalopy B", which also appeared in December.

Thanks went to Ed Miller for allowing the Section to use his launch system at the last two Section Sport Launches, on Dec. 4 and Dec. 11.

Those that attended and flew at the last two Section Sport Launches were commended, condemned, committed, etc. (It was cold!)

The Treasury Report was given, showing \$0 income since the last meeting, with an expenditure of \$12.00 for parts for the club launch system. This leaves a balance in the General Fund of \$77.37.

The Nominating Ballots for the positions on the Section Board of Directors were collected and tabulated. (An election ballot appears elsewhere in this issue.)

Discussion was held on the logo and the proposed club business cards. Dick Rhoat made a motion, seconded by Ed Miller, to direct Section Advisor John Yost to contact a printer, and make arrangements to have 1,000 cards printed, with a budget of \$25.00. The motion was carried by voice vote.

Glenn Feveryear and George Beaver stated that they needed head counts on those who will be attended the two scheduled Winter Workshops, so that kits and parts for kits can be ordered.

John Yost showed the membership a number of forms that he had acquired, concerning tax exempt status for the Section, incorporation, etc. These forms and related questions were tabled for a future meeting.

The SPAAR 1988 Awards were then presented to the membership.

Glenn Feveryear then showed the membership a duration competition model that he had designed and constructed using Apogee Components parts.

General discussion followed, and the meeting adjourned at 9 PM.

\*\*\*\*\*

### Section Launch Activities

After suffering frostbite and related cold weather afflictions at the Section Sport Launch on December 4, the same group of not-ready-for-prime-time-flyers appeared at Cocalico High School on Sunday, December 18, for the regularly scheduled monthly fun fly. This time, however, common sense prevailed, and the flying activity was kept to a minimum. Just about everyone who showed up got in at least one flight, to tide them over to March of '89!

#### FLIGHT LOG

<u>Flight #</u>	<u>Name</u>	<u>Model</u>	<u>Motor</u>	<u>Time</u>	<u>Dur.</u>	<u>Misc.</u>
1	Ed	X-1	1/2A3-4T	1333	24.3	GF
2	George	Turkeybird	1/2A3-4T	1342	36.1	GF
3	Dave W.	Laser	B6-4	1347	28.6	Streamer
4	Dave B.	Excaliber	C6-7	1350	39.5	Streamer
5	Dave W.	Big Blue	B6-4	1404	20.8	GF
6	John	Der Red Max	B4-2	1405	XXXX	CATO
7	Ed	Orion	C5-3	1415	13.4	GF
8	Rick	Scout	A8-3	1426	14.8	GF

FLIGHT LOG (cont.)

Number of participants: 9  
Number of succesful flights: 7  
Number of CATOs, prangs, etc.: 1  
Breakdown of motors fired, by type:  
1/2A3-4T: 2  
A8-3: 1  
B4-2: 1  
B6-4: 2  
C5-3: 1  
C6-7: 1  
Total: 8

Section Records set or broken:  
1. 1/2A Streamer Duration:  
Flight #2, George Beever,  
Turkeybird, 1/2A3-4T, 36.1 seconds.  
Old record: John Yost, Un-named,  
June 5, 1988, 20.2 seconds.  
2. C Streamer Duration:  
Flight #4, Dave Bender,  
Excaliber, C6-7, 39.5 seconds.  
Old record: None.

\*\*\*\*\*  
Election of Officers

The election for the 1989 SPAAR Board of Directors will be held at the January Section meeting. Nominations were taken at the December meeting for the offices involved.

Below is your ballot; fill it out and bring it with you to the Section meeting on Monday, January 16, 1989. If you cannot attend the meeting, or don't think you can attend the meeting, send your ballot to Section Advisor John Yost, 4112 Millbrook Rd., Mt. Joy, Pa., 17552, prior to Jan. 16. The ballots will be kept sealed and only opened at the meeting.

As you can see, a number of the offices listed below show a nominees' name, followed by "Other"; this indicates that no other member received more than 1 nominating vote. If you do not wish to vote for the candidate listed, simply write in the name of the member you are voting for on the "Other" line.

ALL MEMBERS ARE ENCOURAGED TO VOTE! PLEASE TAKE THE TIME TO DO SO!!!

\_\_\_\_\_ Cut Along This Line \_\_\_\_\_

SECTION ADVISOR:

JOHN YOST \_\_\_\_\_

OTHER \_\_\_\_\_

SECTION SECRETARY/TREASURER:

ED MILLER \_\_\_\_\_

OTHER \_\_\_\_\_

SECTION PRESIDENT:

GEORGE BEEVER \_\_\_\_\_

OTHER \_\_\_\_\_

SECTION MEMBER-AT-LARGE: (Vote for one)

DICK RHOAT \_\_\_\_\_

RICK HACKMAN \_\_\_\_\_

SECTION VICE-PRESIDENT: (Vote for one)

GLENN FEVEYER \_\_\_\_\_

DAVE WENRICH \_\_\_\_\_

Section News Notes

On Wednesday, December 21, I spoke by phone with Mr. Becker of Bellville Wholesale Hobbies in Bellville, Illinois, in order to check on his inventory of Estes "Wizard" kits for the January 14 SPAAR Winter Workshop. He assured me that he had as many as we needed, and that we would have them in plenty of time for the workshop. Seventeen of the kits were then ordered. If there are any extra, perhaps they can be used as prizes in future contests. Cost is still only \$3.00 per person.

\*\*\*\*\*

Mr. Becker also advised me that the following Estes kits are going out of production. If one of your favorites is on the "hit list", I suggest you pick one up at your local hobby shop, or order from Bellville Hobbies ASAP, due to the fact that Becker's inventory of discontinued kits is being bought by the Acme Rocket Co. in Arizona, sometime in January.

Sky Hook; Scorpion; Mini Shuttle; Honest John; Sunbird; Mighty Moe; Scout II; Crusader Swing Wing; Interceptor II; Explorer; Gemini-Titan; Clipper; Longshot; D.A.R.T.; TransStar Carrier; Arrow; Mini Mars Lander; & Dragon Fly.

\*\*\*\*\*

In regards to the January workshop to be held on the 14th of the month at the Delta-Cardiff Fire Hall; Glenn has supplied me with directions, which we will pick up from the traffic light at the Buck, which is the intersection of Rt. 272 & Rt. 372. Go west on Rt. 372, over the Norman Wood bridge, to the "T" intersection of Rt. 372 and Rt. 74; Turn LEFT (South) onto Rt. 74, and take 74 South approx. 3 - 4 miles to the intersection of Rt. 74 and Rt. 851. Paper Mill Farms restaraunt will be on the right corner. Turn LEFT onto Rt. 851 at this intersection. Continue on 851 about 1½ - 2 miles until you come to a STOP sign. This will be Main St., Delta. Turn RIGHT onto Main St. Go about ½ mile, and the Delta-Cardiff Vol. Fire Co. will be on the left. Parking is in the rear.

Glenn also advises that the Fire Co. has a soda machine, and that if you do not wish to bring your own lunch, there are two pizza & sub shops in Delta.

Those who wish to car-pool or caravan, let me know prior to the 14th. I plan to leave my house NO LATER than 9:30; somehow, we can make sure everyone gets there!

\*\*\*\*\*

Recently, I received a mailing from Fred Shecter of the Los Angeles Rocket Society, which included an update on their products and price list. I'll try to remember to run copies off and bring them to the next meeting.

\*\*\*\*\*

All members are strongly encouraged to attend the Section meeting on Monday, January 16. There is a lot of important business to attend to, besides the elections. A number of proposals will be introduced for discussion, including the establishment and staffing of committees, an accelorated launch schedule for the warm weather months, the flyers that are to be placed in hobby shops to attract new members, etc.

PLEASE ATTEND AND VOICE YOUR OPINION!

\*\*\*\*\*

From the Broken Record Department: Once again, your editor is asking, no... BEGGING for contributions for the Countdown. This month's Sport Plan was contributed by John Yost, and we are thanking him in advance. The idea behind the Delta Star II was the movie "Delta Force", which featured motorcycle-mounted rockets, of which the Delta Star II is a semi-scale version. Things got so bad that the Competition Plan is one of mine, for gosh sakes! Figure that one out; John's is the Sport Plan and mine is the Competition Plan. Seems kinda backwards. THANKS JOHN!

\*\*\*\*\*

# DELTA STAR II

John Yost  
NAA 31472

## SPORT MODEL

### PARTS LIST

- Estes  
 PNC-50KA  
 TA-2050  
 BT-50 2 inches long  
 BT-20 10 inches long  
 EB-20A
- OTHER  
 3/32 plywood sheeting  
 screw eye  
 3/4 inches of standard  
 launch lug  
 (1/4" upper 1/2" lower)

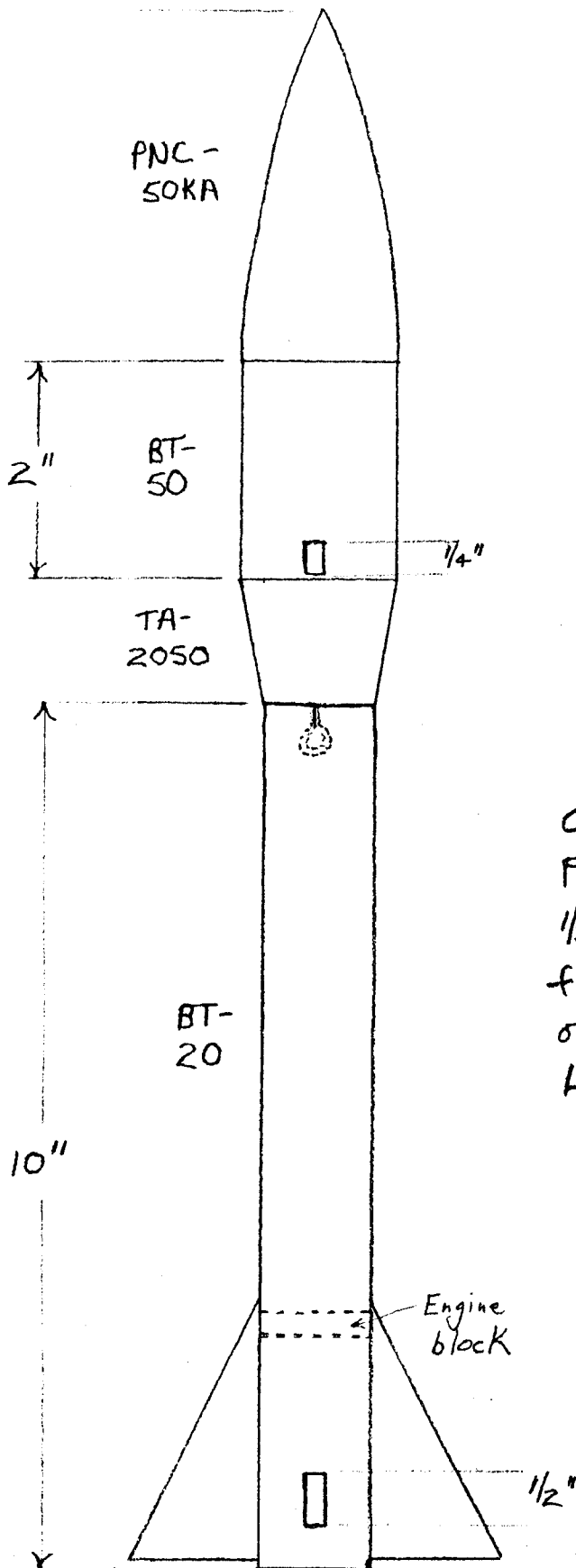

Construction is straightforward and simple.  
 Finish painting is flat or gloss black with  
 1/2" yellow bands (paint or tape) 3 inches  
 from rear of model and 3/8" from bottom  
 of BT-50.

Launch with A8-3 thru B4-6 engines,  
 parachute or streamer recovery.

Fin Pattern  
 Full size  
 make 3 of  
 3/32 plywood  
 or  
 5/32 to 1/8" balsa

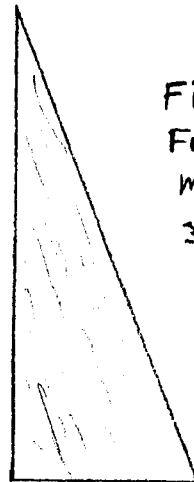

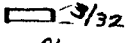
-  3/32 Balsa  
 L.L. Standoff  
 (Lower)
-  3/32 Plywood  
 L.L. Standoff  
 (Upper)

NOT TO SCALE

# The TURKEYBIRD

1/2A-A STEAMER DURATION DESIGN

FOR 13mm MOTORS

George Beever

NAR 44391

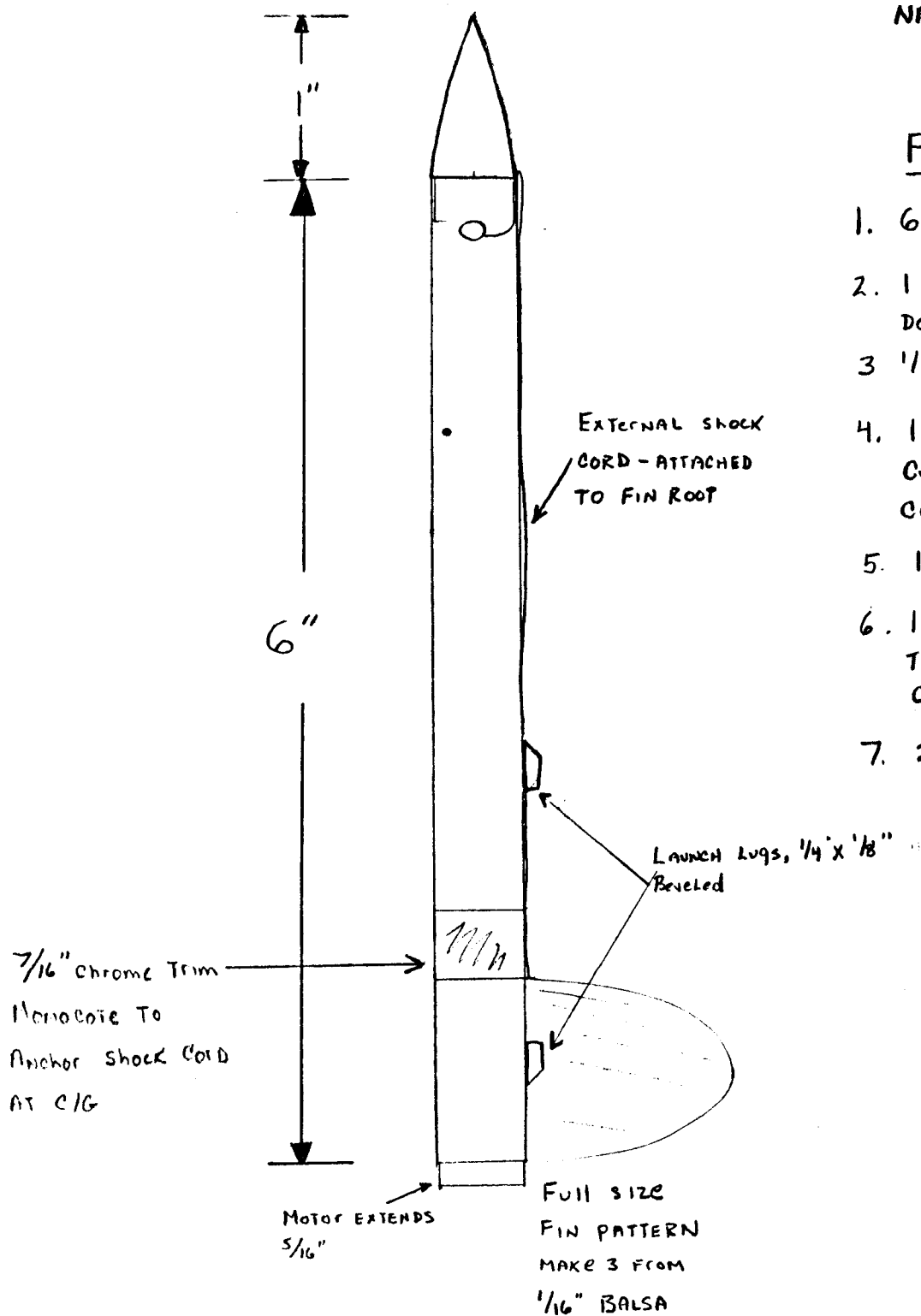

## PARTS LIST (ESTES)

1. 6" OF BT-5
2. 1 BNC-5S, SANDED DOWN TO 1"
3. 1/16" Balsa
4. 1 paper engine block CUT FROM DUMMY MOTOR CASING
5. 1 screw eye (small!)
6. 12" OF HEAVY CARPET THREAD FOR SHOCK CORD
7. 2 1/4" Launch Lugs

ON 18 Dec 88, FLOWN WITH 1/2A3-4T MOTOR AND A 1 1/2" X 15" TRACING PAPER STEAMER TO A 36.1 SECOND DURATION

1988 In Review

Section Launches:

<u>DATE</u>	<u>SITE</u>	<u>RSO/LCO</u>	<u># of Flights</u>	<u># of participants</u>	<u>MISC.</u>
5 June	Cocalico HS	None	20	5	Windy
3 July	Cocalico HS	John Yost	42	9	HOT!
14 August	Comet Field	Rick Hackman	60	16	Warm
9 October	Cocalico HS	Dave Wenrich	61	13	UNCLE-1
30 October	Cocalico HS	G. Beever/D. Bender	26	8	COLD
4 December	Cocalico HS	Ed Miller	26	10	COLDER
18 December	Cocalico HS	D. Bender	8	9	COLDEST!

TOTALS: 7 Launch Dates, 243 flights.

\*\*\*\*\*

Flights per Person

<u>John Yost</u>	<u>Daniel Yost</u>	<u>Derek Yost</u>	<u>Rick Hackman</u>	<u>Dave Wenrich</u>	<u>Jess Wenrich</u>	<u>Wenrich Bros.</u>	<u>Ed Miller</u>	<u>Dave Bender</u>	<u>Bill Rhoat</u>	<u>Tim Singles</u>	<u>Mike Singles</u>	<u>Mark Snyder</u>	<u>Glenn Feveryear</u>	<u>Dan Weinhold</u>	<u>George Beever</u>	<u>Bryon Beller</u>	<u>Dayna Weinhold</u>	<u>Kirk Palm</u>	<u>John Schuler</u>	<u>Kevin Reichert</u>	<u>TOTAL</u>	<u>DATE</u>
7	0	0	3	0	0	5	x	x	3	x	x	x	x	x	2	x	x	x	x	x	20	June 5, 1988
2	2	3	7	x	x	x	x	x	5	6	2	8	x	x	7	x	x	x	x	x	42	July 3, 1988
3	2	2	3	0	0	5	6	5	5	5	0	x	4	8	5	x	1	3	1	2	60	August 14, 1988
5	3	1	10	2	1	0	5	10	5	x	x	x	4	7	7	x	1	x	x	x	61	October 9, 1988
0	0	0	4	3	0	0	6	5	1	x	x	x	3	x	3	1	x	x	x	x	26	October 30, 1988
2	1	1	7	2	2	0	5	3	1	x	x	x	x	x	2	0	x	x	x	x	26	December 4, 1988
1	0	0	1	2	0	0	2	1	x	x	x	x	x	x	1	0	x	x	x	x	8	December 18, 1988
20	8	7	35	9	3	10	24	24	20	11	2	8	11	15	27	1	2	3	1	2	243	7 Dates

\*\*\*\*\*

Congratulations to SPAAR's Bill Rhoat for being named to the Honor Roll (11th grade) at Ephrata Senior High School.

\*\*\*\*\*



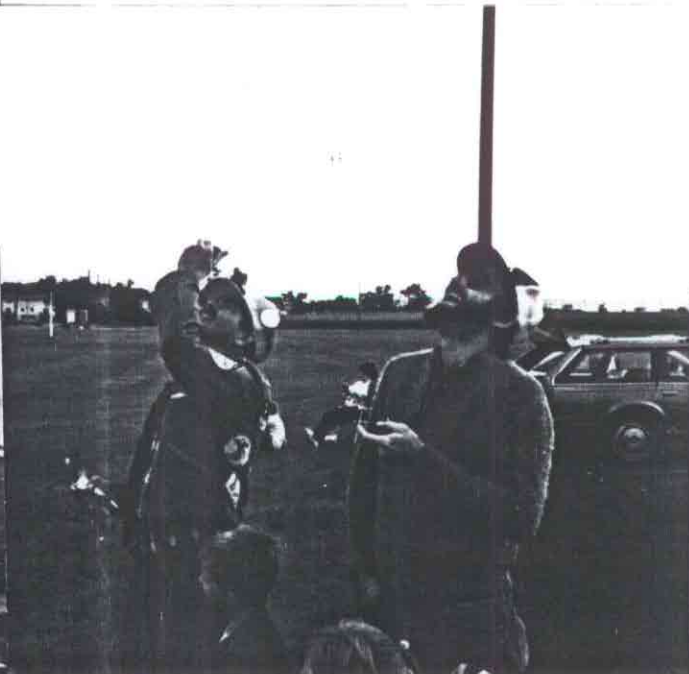
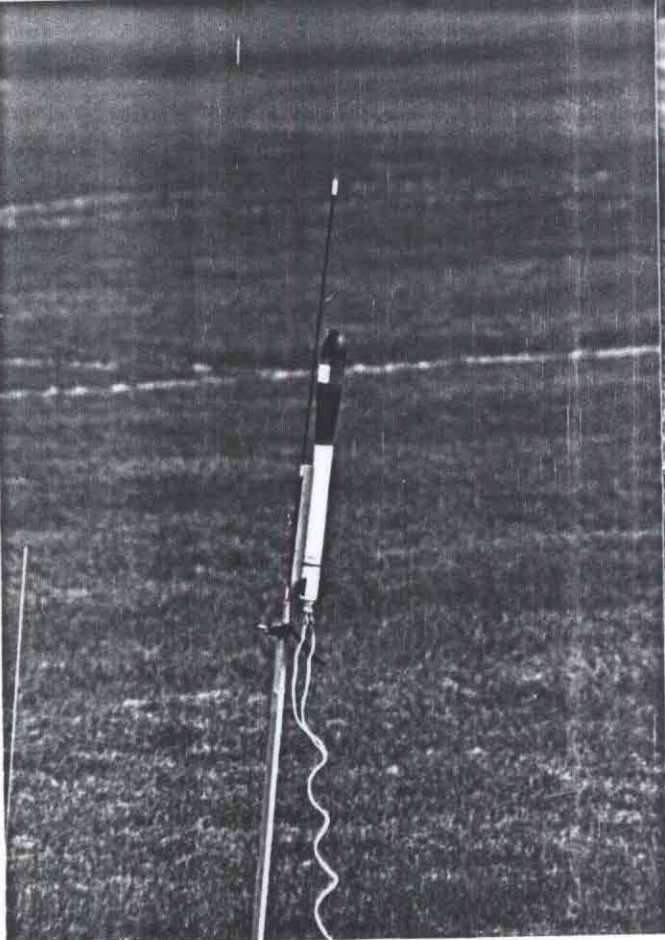

Scenes FROM  
SPAAR '88

