

*The Southern Pennsylvania Area  
Association of Rocketry*

# COUNTDOWN

Volume 2 No. 6  
November 1989

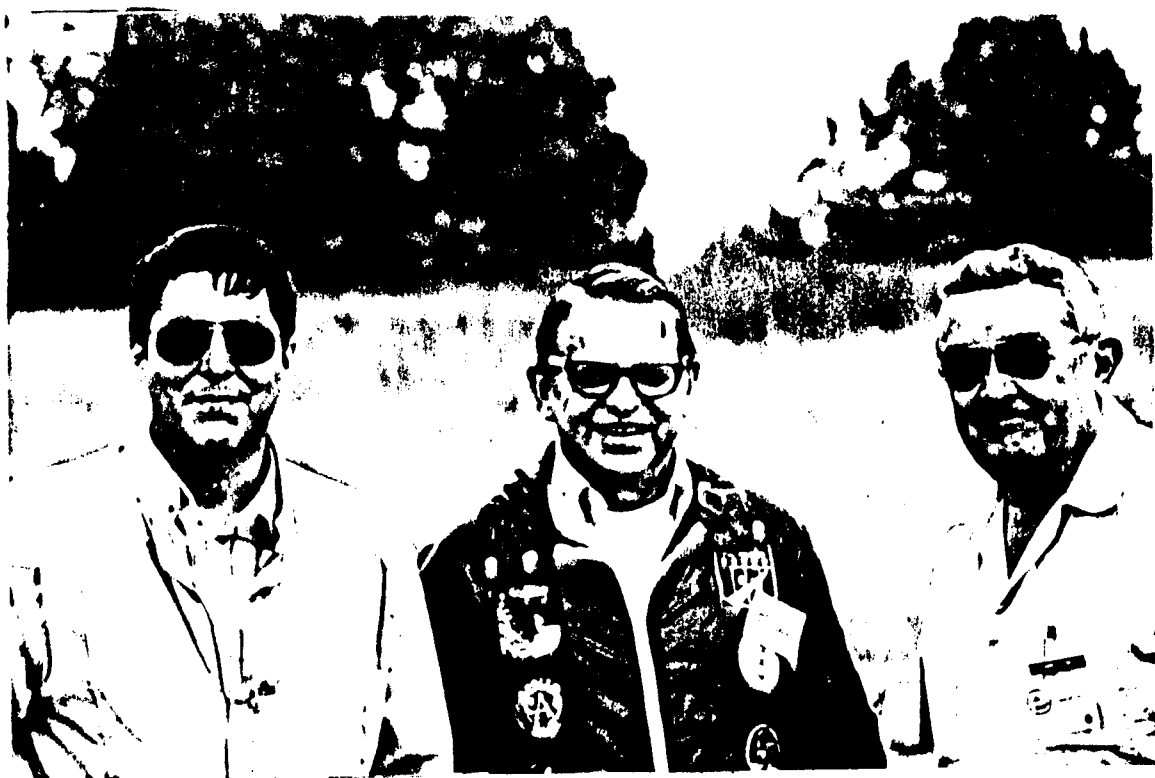

**The 3 most famous names in model  
rocketry— Vern Estes, G. Harry  
Stine, & ... ED MILLER?! ?!**

THE SPAAR COUNTDOWN

Volume 2, Number 6

November, 1989

The SPAAR COUNTDOWN is the official newsletter of the Southern Pennsylvania Area Association of Rocketry, P.O. Box 127, Reamstown, Pa., 17567, and is intended for the enjoyment of it's members and subscribers. Non-member subscription rate, \$5.00 per year.

Thanks this month to:

Bruce Canino & Rick Hackman

Table of Contents

Editorial:  
    Needed: A new launch sight.....Page 3  
SPAARSPAM-1.....Page 4  
Flight Log, 11/5/89.....Page 5  
Section News Notes.....Page 5  
The JOISEE-V Regional Meet.....Page 6  
The Latest Rumours.....Page 7  
Sport Plan: the XR-52.....Page 8  
Election Ballot.....Page 9

CALENDAR

SATURDAY, DEC. 9, 1989

10 AM to 4 PM: Section building session; Pizza & Videos; Delta Fire Co., Delta, Pa.  
Contact: Glenn Feveryear (717) 456-5570; George Beever (717) 733-4170; or John Yost (717) 684-9519 for information.

SATURDAY, JAN. 27, 1990

10 Am to 4 PM: Section building session; Helicopters; Delta Fire Co., Delta, Pa.  
Contact: Glenn Feveryear (717) 456-5570; George Beever (717) 733-4170; or John Yost (717) 684-9519 for information.

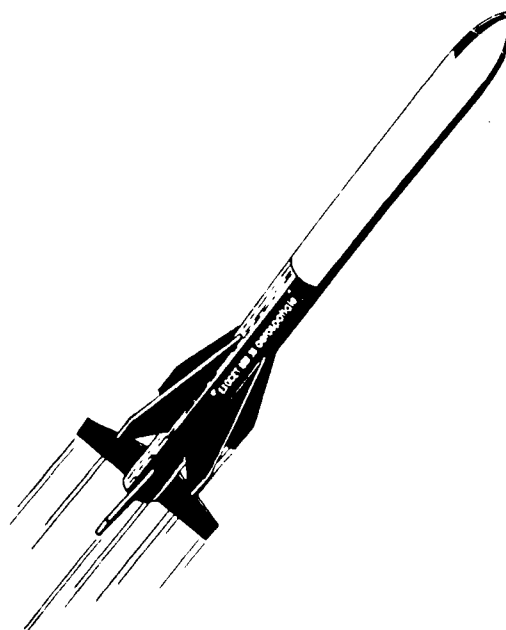

EDITORIAL

On November 5, SPAAR held it's last launch of 1989, at Cocalico High School in Denver. All previous club launches have taken place there, except for one occasion, when Comet Field in Lancaster was used.

I personally hope that this was the last launch the club ever has at Cocalico.

That may sound a bit drastic, but I hope it highlights what I feel is one of the major needs of this club: A good, accessible flying field, that is free of restrictions and interference. Let's face it, we don't have that at Cocalico. At least not anymore.

I started flying model rockets at Cocalico High School in 1978. At that time, on any given Sunday (or Saturday, for that matter), one could have your pick of wide open spaces. It seemed that no one used the facilities there for anything on weekends. Even the housing development across the street wasn't there!

However, as the Northern Lancaster County area has boomed economically, the population has risen; Lancaster County is now the fourth most populated county in the state, and it is still growing; and the growth has been greatest in the area north of Ephrata. As the population grows, so does the need for recreational space. In this area, that means Cocalico High School.

This region, for example, seems to be particularly fond of softball. There are dozens of leagues which play almost every night during the week, and on Saturdays and Sundays. That means Cocalico. The local soccer leagues now use Cocalico on Sunday afternoons in the fall, because the fields that they used to use are now housing developments. It's not going to get any better.

At the present time, we have an inquiry at Hershey for possible use of a field near Hershey Park. As of this writing, however, no response has been received. A facility such as this, which is close to major highways, with motel facilities nearby, is a must if we ever hope to hold a successful Open or Regional Meet in the near future.

We could, of course, continue to fly at Cocalico. That's providing that we want to put up with being sandwiched between a softball game on one side, and a soccer game on the other. Our unwritten agreement with the Cocalico School District states that sporting events get priority at School District facilities; other than that, we're more than "welcome".

A model rocket club with no place to fly will cease to exist. One doesn't need to be "a real rocket scientist" to figure that one out.

As winter approaches, our club stops flying as a group until warmer weather returns in the spring. However, I feel that this issue should not be put off until spring. The winter months should be used by us to explore the possible use of other areas to hold club launch activities.

It is sometimes easy for us to say "let the other guy worry about it." I hope we don't say that now, on this issue. We all have to be the "other guy". I urge all members to look around, keep an eye out for possible new launch facilities. Write the information down on a piece of paper if that will help you to remember who the owner of a certain property is. Bring the information to the next club meeting, share the information so that a course of action can be decided upon.

Become involved!

SPAARSPAM-1

On November 5, SPAAR members and their families got together for the season's last club launch, the so-called SPAAR Section Picnic And Meet, SPAARSPAM-1.

It was a day filled with good freinds, good food, and doing what we all like to do best... and we even got in some model rocketry, too.

Those who couldn't make it missed out on some world class hot dogs, courtesy of Jim Lytle, who showed that he can cook a frank as well as he can build and fly his Saturn V. There was Deb Yost's pasta salad, and she went to great pains to let us know that it was husband John who cut the pepperoni and cheese to such exact portions. Ed Miller came with some of his wife's "rocket cookies" which had to have been seen to be appreciated. And if all of that didn't fill you up, there was Teresa and George's chili, mild version. Not to mention all of the other goodies such as soda, chips, and cheeses, and all of the other contributions such as cups, plates and bowls wouldn't be fair!! This was truly a group effort, one that we hope is repeated next year at SPAARSPAM-2!

In between all of this eating, we even flew two "events", Drag Race, as per "pink book" rules, and a Bill Rhoat creation,  $\frac{1}{2}$ A Micro-Roc Non-Duration.

The Competition was fierce in both events. After a tough battle, Eric Marcella edged out John Yost in Drag Race, with Dave

Bender taking third and Bill Rhoat coming fourth.

John avenged himself in Micro-Roc, however, by taking the first in this event with a specially modified "Birdie". Aaron Newman, Bill Rhoat, and Dave Bender finished second through fourth, respectively.

Of the 65 total flights made November 5, 42 of them were sport flights. Strangely enough, a good number of these flights are best forgotten!!

The first of these was George Beever's ill-fated "Maxi-Rotaroc", trying for a club E Helicopter record. That record is still up for grabs. Just as it did at WUBBA it boosted just fine... but after that, oh well. The good news is that after this crash, it can't be resurrected. We're all much safer.

Glenn Feveryear took first place in Sport Scale at JOISEE-V with his FSI Black Brant II. On November 5 he took it home in peices. The E60 CATO'd with the expected results.

Ed Miller brought out his NCR ASAT-21X with a G80, but the parachute separated from the model at deployment. Ed builds 'em strong, though, and the model was not damaged.

In all honesty, the good flights outnumbered the bad. As mentioned, Jim Lytle flew his Saturn V, as did George Beever. Rick Hackman flew some more "XR" rockets; Fred Hoke brought some more two-stage "D" rockets; Aaron Newman did some very nice flying, including a home-built semi-scale Delta V; and Dick Rhoat finally got a chance to try out his new tower with an A SRD bird.

Sight: Cocalico HS		FLIGHT LOG		Date: 5 Nov 89		
FLIGHT #	NAME	MODEL	MOTOR	TIME	EVENT	MISC
1	G. Beever	Maxi RotaRoc	E60-4	XXXXXX	E HD	PRG
2	M. Snyder	Marauder	B6-4	XXXXXX	Sport	GF
3	J. Lytle	Saturn V	D12-3	XXXXXX	"	"
4	E. Miller	Sentinel	C6-5	XXXXXX	"	"
5	R. Hackman	Alpha 3	B4-4	51.75	"	"
6	A. Newman	Delta V	C6-5	16.69	"	"
7	G. Feveryear	Black Brant	E60-6	10.44	"	CATO
8	A. Newman	Thunderbird	B6-4	10.22	"	"
9	E. Miller	Warp Drive II	F100-10	64.5	F SD	GF
10	A. Newman	Zaxxon Ftr.	B4-4	13.34	Sport	GF
11	J. Lytle	Astrocam 110	B8-5	8.5	"	"
12	J. Lytle	Astrocam 110	C6-5	20.35	"	"
13	M. Snyder	Explorer	C6-5	XXXXXX	"	"
14	R. Hackman	XR-54	C6-3	42.56	"	"
15	G. Feveryear	Grumpy Dog	D12-0/D12-7	XXXXXX	"	CHU
16	G. Beever	RotaRoc-C	C5-3	91.85	C HD	NR
17	D. Rhoat	A SRD	A3-6	20.94	A SRD	GF
18	D. Rhoat	A SRD	A3-2	26.00	A SRD	"
19	F. Hoke	Crusader S/W	B6-2	12.53	Sport/ B B/G	"
20	A. Newman	Snark	B6-4	25.65	Sport	"
21	R. Fuld	Viking	C6-5	54.0	"	NR
22	W. Rhoat	Onyx	E60-6	22.19	"	"
23	A. Newman	Soviet Shuttle	C6-5	9.59	"	"
24	R. Fuld	No Name	A10-3	14.41	"	"
25	R. Fuld	No Name	A10-3	2.0	"	?
26	G. Beever	Saturn V	D12-3	15.6	"	"
27	R. Hackman	XR-55	C6-3	19.2	"	"
28	F. Hoke	Phoenix +	D12-0/D12-3	37.1	"	"
29	E. Miller	ASAT-21X	G80-7	24.00	"	SEP
30	R. Hackman	XR-57	C6-7	53.5	"	GF
31	F. Hoke Super	Big Bertha +	D12-0/D12-5	35.78	"	"
32	D. Greene	Dual Eggloft	D21-4	XXXXXX	D DEL	SEP
33	F. Hoke	Der V-3+	D12-0/D12-5	76.0	Sport	?
34	E. Miller	Double Take	C6-0/B4-6	22.00	"	GF
35	E. Marcella	Mini Mean Mach.	A10-3	15.6	"	"
36	E. Miller	Pathfinder	C5-3	21.7	"	"
37	R. Fuld	Starbird	B4-4	29.39	"	"
38	R. Fuld	Starbird	C6-3	60.00	"	"
39	E. Marcella	Eggspress	C6-5	46.2	"	"
40	D. Greene	Flatcat	A8-3	21.65	A B/G	"
41	D. Greene	Flatcat	B4-2	9.9	B B/G	RB
42	R. Hackman	XR-61	D12-3	51.2	Sport	GF
43	A. Newman	Mini Mars Land.	1/2 A3-2	6.0	MicroRoc ND	"
44	A. Newman	"	"	6.08	"	"
45	W. Rhoat	"	1/2 A6-2	6.03	"	"
46	R. Hackman	Short Snort	1/2 A6-2	5.7	"	"
47	D. Bender	Liberty	1/2 A6-2	6.9	"	"
48	J. Yost	Birdie	1/2 A3-2	5.38	"	"
49	J. Yost	"	1/2 A3-2	3.76	"	"
50	G. Beever	Rebel	1/2 A6-2	"	Drag Race	CHU
51	G. Feveryear	"	1/2 A6-2	"	"	ND
52	D. Bender	"	1/2 A6-2	"	"	GF
53	R. Hackman	"	B8-5	"	"	"
54	A. Newman	"	1/2 A6-2	"	"	"
55	E. Marcella	"	A10-3	"	"	"
56	W. Rhoat	"	A8-3	"	Drag Race	GF
57	D. Rhoat	"	A8-3	"	"	"
58	H. Snyder	"	1/2 A6-2	"	"	"
59	J. Yost	"	1/2 A6-2	"	"	"
60	D. Bender	"	1/2 A6-2	"	"	"
61	E. Marcella	"	C6-5	"	"	"
62	W. Rhoat	"	A8-3	"	"	"
63	J. Yost	"	1/2 A6-2	"	"	"
64	E. Marcella	"	A10-3	"	"	"
65	J. Yost	"	1/2 A6-2	"	"	"

DUES NEWS

Because a large number of member's dues are owed at this time of the year, Treasurer Ed Miller asked the Countdown to print a list of those members whose annual dues are to be paid by 1/1/90: E. Miller; D. Bender; G. Beever; Mark, Carl, & Chris Snyder; D. Weinhold; J. Shaffer; D. Rhoat; B. Rhoat; D. Greene; Dave and Jess Wenrich; R. Hackman; G. Feveryear; John, Daniel & Derek Yost; K. Reichert; T. Beever.

The dues rates remain the same: 14 years of age or younger, \$5.00 per year; 15, 16, or 17 years of age, \$7.00 per year; 18 years or older, \$10.00 per year. If you wish to pay by check, make your checks payable to: SPAAR, c/o Ed Miller, 1809 Quarry Rd., Lebanon, Pa., 17042, or SPAAR, PO Box 127, Reamstown, Pa., 17567. Sorry, Ed doesn't take Mastercard or Visa.

Those members who are not on the above list will be notified by post card of when their dues come up.

\*\*\*\*\*

Again, all members are urged to attend our business meetings, held on the third Monday of

each month, at the Lancaster County Public Library, on N. Duke St. in the city. Meetings start at 7 PM and run until 9 PM. This is your opportunity to express your thoughts and ideas. Please plan to attend!!!!

\*\*\*\*\*

Even though there are no SPAAR club launches scheduled until next Spring, I'm sure that SPAAR members will continue to fly rockets during the coming months. Sounds like a good idea for an article. Send it in!!

Glenn Feveryear reports that he has located a source for purchase of 1/4 mil polyethylene plastic parachute material. These cleaner bags are blue in color, and can only be purchased by the roll, which costs \$35.00 or thereabouts. Glenn says that if enough people want to pitch in purchase a roll, it would be cost effective. Call Glenn if you are intersted.

The JOISEE-V Regional

The JOISEE-V Regional, hosted by the Garden State Spacemodeling Society was originally scheduled for the weekend of 23-24 September, but a fellow named Hugo caused a postponement to the weekend of October 21-22.

SPAAR members Glenn & Rita Feveryear, Dale Greene, and George Beever made the trip to compete. Glenn and Rita planned to stay the entire weekend, but prior commitments dictated that Dale and George could only fly on Saturday, the 21st.

The reception we received from the GSSS members was, as usual, very warm and friendly. The same, however, cannot be said for the weather. A cold, raw wind blew all day on Saturday, gusting at times up to 20-25mph, with the threat of rain all day. Oh well, ya' can't have everything!

Most folks started their flying on Saturday with B Eggloft. Glenn took first with a 62 second flight, after suffering a separation on his first flight. Dr. Bob! Kruetz took second with a 27 second flight- which should give some idea of the havoc the wind was playing with the big eggloft-type 'chutes.

B Streamer and A Boost/Glide were contests to see if you could just return a flight; chances were, if you could do that, you could place! SPAAR did very well in these two events; Glenn and George took first and third, respectively, in B SD, and Dale and George finished first and second in A B/G, with Glenn taking fourth.

The combined A & B Divisions were dominated by The Whymark brothers and Ed Glombocki, all of GSSS. In fact, with the exception of Jason Gourley, who flew as an independant, all of the A & B divisioners were GSSS members. Bill Rhoat, where are you?

With the wind and weather being as it was,  $\frac{1}{2}$ A PD was an interesting game of strategy.  $\frac{1}{2}$ A6-2's and 18mm body tubes suddenly regained popularity, as contestants tried to figure a way to return models. With some good fortune, strong legs to hike with, and good eyes to follow smaller models, the smaller 13mm models still proved to be the winners. Glenn Feveryear took a first place in C Division with flights of 82 and 23 seconds, for a 105 second total. He barely beat out GSSS's Single Again team, who logged 103 total seconds. Third place went to Dr. Bob! with 99 seconds. Six seconds separated the first, second, and third place winners!

There were a few C SuperRocs flown on Saturday, including George's, which is still stuck somewhere in a Jersey swamp, for a No Return. Glenn eventually took first place, with 1105 total points. A very small chute or even a streamer was what was needed in this event.

Sunday was the day for Sport Scale and Plastic Model Conversion. Saturday's static judging gave Glenn 645 points on his FSI Black Brant II. On Sunday, he flew it with an E60-6 and garnered 190 flight points, for a first place total of 835 points. GSSS swept PMC, with the Single Again team taking first, and Dr. Bob! and his MMU Man taking second.

SPAAR did well for itself at this meet; we took (or should we say Glenn took) first place in B SD,  $\frac{1}{2}$ A PD, C SRD, B ELD and Sport Scale; Dale took the first in A B/G and third in B ELD; George took second in A B/G, third in B SD, and fourth in  $\frac{1}{2}$ A PD.

As is usual at a GSSS meet, the main object is to have fun; as Dr. Bob!  
(con't. on page 9)

# ...And for the Latest



## RUMORS

Hobbies in California.

Cox has long been involved in the gas powered model aircraft feild, and during the model rocketry boom of the late sixties, became involved in that hobby. They marketed a line of already built rockets, such as the Saturn V and Saturn 1B. They also offered a series of motors in the A, B, and C range. However, a fatal accident at their engine manufacturing facility in 1972, led Cox to abandon model rocketry.

Now, with the resurgence of the hobby, comes word that Cox will reintroduce the same line of ready-built models, as the same molds used in the late sixties were located in good condition.

A September reintroduction date was postponed, but Cox reportedly expects to have product on the shelves in time for Christmas.

There are those who dislike the types of products that Cox plans to offer, feeling that the ready-made aspect makes them appear to be more like toys than model rockets, and this may be true. However, competition in the market-place can only benefit, us, the consumers of rocketry products.

\*\*\*\*\*

### CELESTIAL ENTERPRISES

Celestial Enterprises, of Ft. Worth, Texas, is going out of business,

### COX TO RE-ENTER

### MODEL ROCKETRY?

One of the biggest stories making the rounds involves Cox

according to owner Sam Baxter.

In mid-August, Dick Rhoat and George Beever ordered Celestial Enterprises launch towers, after seeing examples at NAR meets in New Jersey and Virginia, for use at VACUUM-15 and JOISEE-V.

After a wait of about 6 weeks, contact was made with Mr. Baxter, who stated that he was backlogged with orders for the towers, mostly orders taken at NARAM-31. He also stated that he had attempted to find a business partner for Celestial Enterprises, due to the work load and time involved. By mid-October, failure to find someone suitable has forced Baxter to cease operations.

Celestial had offered a line of body tubes and nose cones, as well as parachutes and streamers for large, high power rockets.

\*\*\*\*\*

From WARP-9, the fine newsletter of DART (San Diego, CA) comes word that MRC will introduce a line of model rocketry products somewhat more advanced in nature than the kits already available.

In addition, AeroTech, a manufacturer of composite motors, is reportedly ready to release an expanded line of products, including a number of items that the now-dunct Enertek was to have sold. These include the "Mantis" launch pad and the "Initiator" kit.

\*\*\*\*\*

SPORT PLAN: THE XR-51 (next page)

The XR-51 is yet another creation of Rick Hackman's imagination. Also called the "Mini Mortar Round", the original flies well, and yours will, too, if one remembers to drill out the TA-550 to allow the ejection gasses to pass! Paint olive drab, and have fun!

SCALE: 1:1

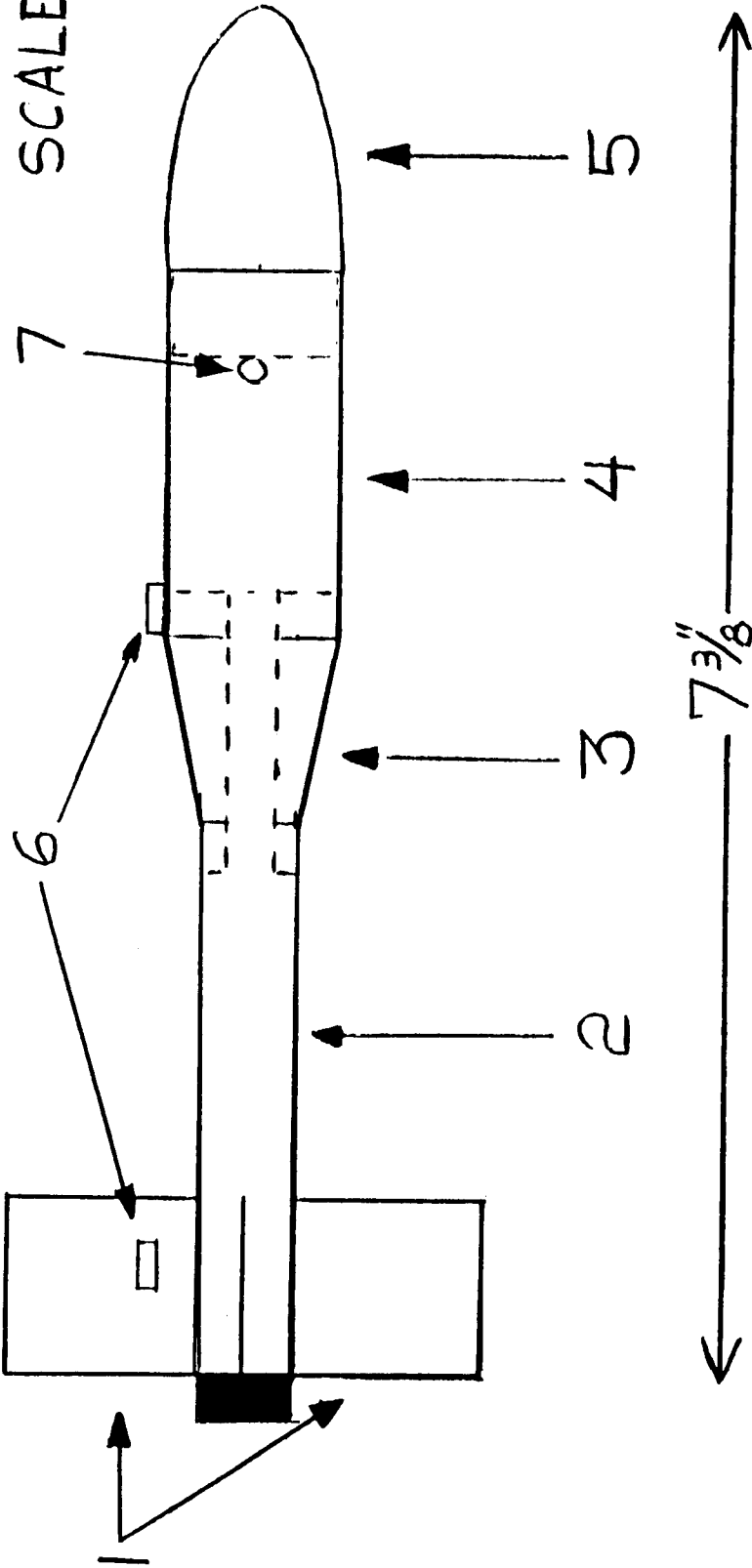

PARTS LIST

NO.	QUAN.	DESCRIPTION
1	4	1" x 1" x 1/16" FINS-BALSA
2	1	3" BT-5
3	1	TA-550
4	1	2" BT-50
5	1	BNC-50J
6	2	1/4" x 1/8" Launch Lugs
7	1	SCREW EYE

NOT SHOWN:

JT-5C ENGINE BLOCK  
SHOCK CORD, STREAMER

NAME: XR-52

DATE: 11-13-89

DESIGNED BY:  
R. HACKMAN

DRAWN BY:  
G. BEEVER



JOISEE-V, con't.

stated, "our contests are rather relaxed and low-keyed". Without meaning to leave anyone out, tons of credit, as well as our thanks go to Jack Sarhage, Bob Zabriskie, Bruce Canino, Don Sayre and Dr. Bob! Kruetz of GSSS. They've promised (or threatened, as the case may be) to come to Pennsylvania next year and return the favor!!

\*\*\*\*\*

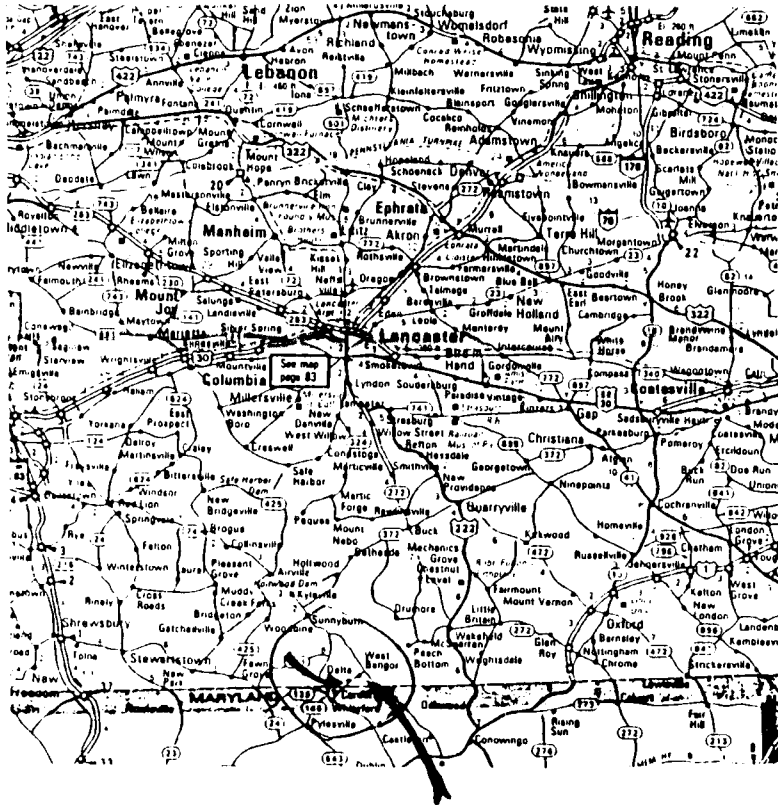

NO, YOU'RE  
NOT  
TOO FAR AWAY  
TO COME TO A  
SPAAR WINTER  
WORKSHOP!!!!

FOR DIRECTIONS, CALL:(in Pa.)  
Glenn Feveryear 717-456-5570  
George Beever 717-733-4170  
John Yost 717-684-9519  
in Maryland:  
Mark Snyder 301-256-7499

\*\*\*\*\*

ELECTION BALLOT

Vote for one. Return, no later than Monday, 12/18/89, to:  
SPAAR Elections, PO Box 127, Reamstown, Pa 17567. Thanks.

For Section Advisor:

- 1. \_\_\_\_\_
- 2. \_\_\_\_\_

For President:

- 1. \_\_\_\_\_
- 2. \_\_\_\_\_

For Vice-President

- 1. \_\_\_\_\_
- 2. \_\_\_\_\_

For Secretary/Treasurer:

- 1. \_\_\_\_\_
- 2. \_\_\_\_\_

For Member-at-Large:

- 1. \_\_\_\_\_
- 2. \_\_\_\_\_

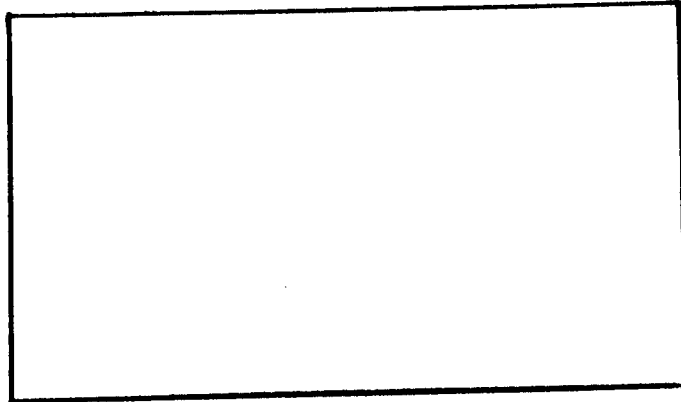

**:01**

S.P.A.A.R.  
P. O. Box 127  
Remington, PA 17567

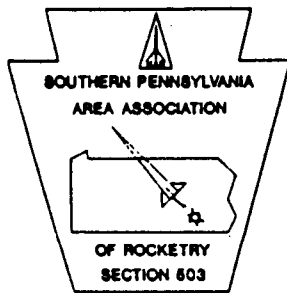

**SOUTHERN PENNSYLVANIA  
AREA ASSOCIATION  
OF ROCKETRY**

**PROMOTING SAFE MODEL ROCKETRY  
IN SOUTHERN PENNSYLVANIA  
AND NORTHERN MARYLAND**

*The Southern Pennsylvania Area  
Association of Rocketry*

# COUNTDOWN

**Volume 2 No. 6  
November 1989**